

ML 600 Series Magnetic Locks

The ML Series is a superior quality magnetic locking device offering up to 600Lbs for single door and double door holding force. The range of applications can be used in customised architectural housings and commercial buildings.

As industry standard, ML Series electromagnets are suitable for outswing doors but can be converted for use on inswing doors using a series of Z and L brackets.



SPECIFICATION

Voltage	12V/24VDC (Selectable)
Current Draw	500mA/12V, 250mA /24V
Holding Force	600 LBS
Sensor	Lock Status, Door Status
Adjustable mounting plates	L, ZL, Adjustable L, U Bracket
Special Finish	Zinc (on the magnet & armature plate)
Housing	Anodized Aluminum

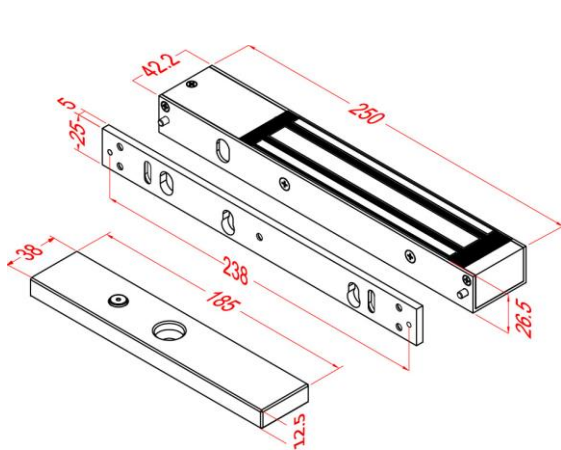

RD01600L

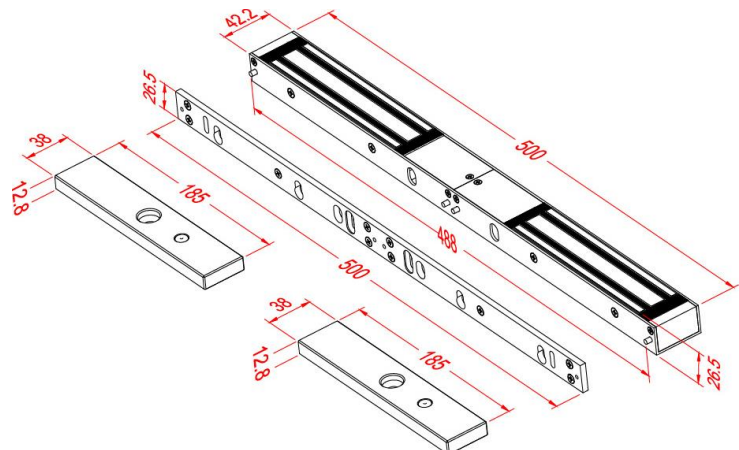

RD01600DL

Product Code	Function/Description
RD01600L	Magnetic Lock 600 Lbs with Lock Status Sensor
RD01600LS	Magnetic Lock 600 Lbs with Lock Status Sensor, Door Status
RD01600DL	Magnetic Lock 600x2 Lbs Double Door with Lock Status Sensor
RD01600DLS	Magnetic Lock 600x2 Lbs Double Door with Lock Status Sensor, Door Status
RD01600L-L	L bracket for use with RD1600Lx / RD11200Lx magnetic locks
RD01600DL-ZL	Z and L bracket set for use with RD1600Lx magnetic lock
RD01600L-ALB	Adjustable L Bracket for use with RD1600Lx magnetic lock
RD01600L-UB	U Bracket for use with RD1600Lx magnetic lock