

ML SERIES 1200P

FEATURE

Horizontal or vertical installation, Special mounting plate for fast, effort-saving, and simple installation, Anti-dismounting and Anti-falling function



SPECIFICATION	
Voltage	12V / 24VDC (Selectable)
Current Draw	500mA/12V , 250mA /24V
Holding Force	about 1200 LBS
Built-in voltage spike suppressor	
Special Finish	Zinc (on the magnet & armature plate)
With Bi-color LED	
Anodized aluminum housing	
Adjustable mounting plate for appropriate and easy installation	
The length can be added according to customer's request	

DIMENSION	
Magnet (ML01)	266L*73W*40D mm
Magnet (ML02)	532L*73W*40D mm
Armature Plate	185L*61W*16T mm

ORDERING INFORMATION

RD011200LS Magnetic Lock 1200 LBS with Lock Status Sensor

RD011200DLS Magnetic Lock 1200 LBS Double Door with Lock Status Sensor

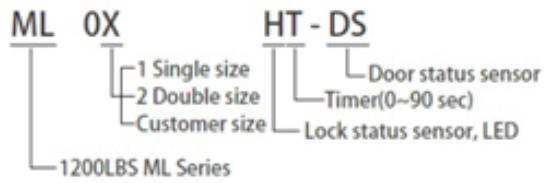

< RD011200 >

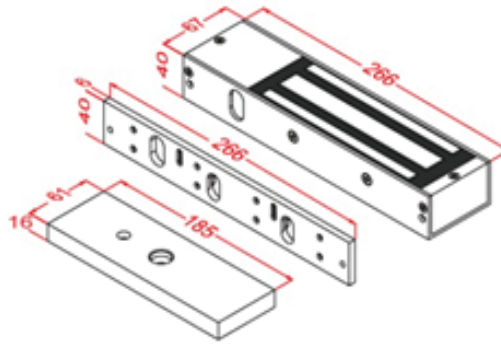

< RD011200 >

